

TB388 Time switch

BERME

- Read the instruction carefully before using it to ensure correct construction.
 - The workers must have recognized electrical construction qualification by government
- Save these instructions

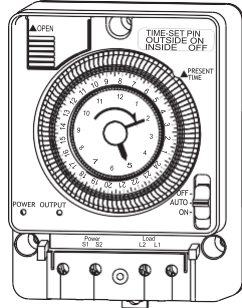

BERME COMPANY

WARNING

- Do not use the time switch in any equipment that supports human death or significant social problems and this switch is specifically not intended for such applications.
- If you want to use the time switch in equipment that could cause a financial loss if a failure occurs (such as in heaters and refrigerators), select a model with excess capacity in terms of characteristics and performance. Then also take safety measures such as providing duplicate circuits.

CAUTION

- Do not repair it by yourself, break down, or reform. Otherwise it will cause shock, fire or failure.
- Please use the appropriate power wire. If you use appropriate power wire, it will lead to a damaged or fire.
- Please connect the bolt of terminal firmly. It will lead to a damage or fire if loose.
- Do not use the time switch where it might be splashed by water or oil. You may receive an electrical shock, cause a fire, or damage the switch.
- Please cut the main power supply before you operation inspection it. Otherwise, you may be shocked by the electric.
- Do not connect to the rated power outside of the power supply. Or it will cause a fire and damage.
- Please do not directly control the load which is above the rated load. It will lead to a damaged or fire. In this case, please use the electromagnetic contactor and other equipment.

Attention in the construction

- Do not use it in the following situations. Otherwise it will lead to malfunction, failure or leakage.
 - The use of places below -10°C or above $+50^{\circ}\text{C}$
 - Such as rain or sunshine outdoors directly the place
 - The place where condensation of dew.
 - The place where with sulfuric acid gas or ammonia and other corrosive gas
 - The using place with heavy moisture or more powder
 - The place where occurs vibration or shock.
 - High frequency noise, electric field, magnetic field strong places
- Output circuit same as the power circuit TB388 type, the output voltage same as the power circuit voltage.
- Please do not put the power terminal and the output terminal of confusion.
- Load capacity exceeds the rated load of the occasion, or load for the three-phase load situation, please use the electromagnetic contactor and other equipment.
- Construction ended, please fully confirm the correctness of the connection, and then the main power supply is switched on for trial operation.

About Nickel metal hydride battery compensation

- About time power compensation
The timing switch has built-in power compensation of nickel-hydrogen battery.
 - If the timer switch is switched on, nickel-metal hydride batteries start charging automatically.
 - The timer will be full of power after three days of continuous switching.
 - Power outages or exceed the power cut compensation time long time power failure will make the battery life.
- Nickel metal hydride battery replacement method
Battery life of about 3 years, the use of higher temperature, life will be more shortened. So please advance the battery replacement. (model: TBS01003)

CAUTION Please be sure to cut off power supply before replace the battery. Or have the risk of electric shock

1. Remove the battery cover.
2. Take the nickel-hydrogen battery out of the battery compartment and disconnect the connector
3. Connector to the new battery, and store the battery in the compartment
4. Make sure to put the battery cover back on.

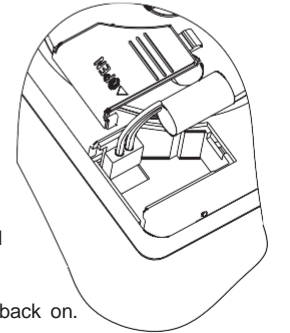

① How to install

- To install the time switch on a wall or other vertical surface. Fix the switch at the three holes with screws or the like. (fixing pitch (Unit:mm))

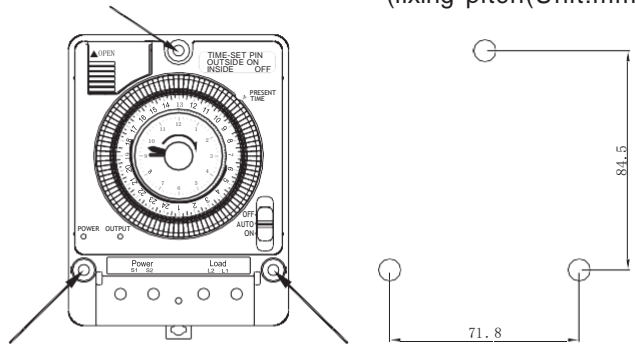

② When use the DIN rail

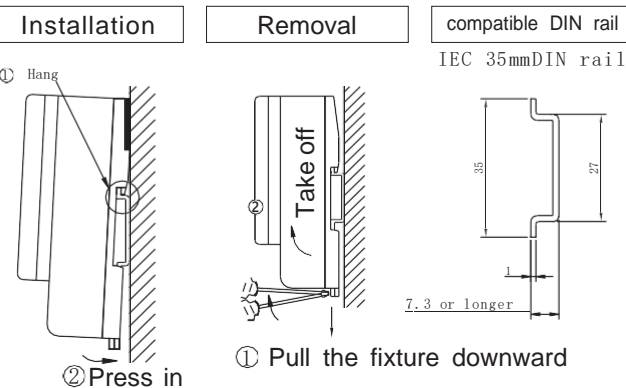

② Wiring examples

- Suitable wire (Please use 600V plastic insulated wire)
 - singlet wire..... $\Phi 1.2 \sim \Phi 2.0 \text{ mm}$
 - Stranded wire..... $1.25 \sim 2 \text{ mm}^2$

Caution

1. The use of inappropriate wire will become a fire damaged or the cause of the fire.
2. Please do not use welding wire. The welding line is not firm and caused by poor contact will be the cause of the fire.

Wire processing

When using a single wire

- Strip the cover back $14 \pm 2 \text{ mm}$.

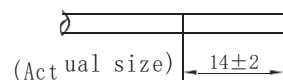

- Please connect the wire to terminal as shown below

Tighten the screw on the terminal block securely
Please insert the wire complete to make the wire head contact this surface

- Appropriate torque $1.2 \sim 1.6 \text{ Nm}$ ($12.2 \sim 16.3 \text{ kgf cm}$)

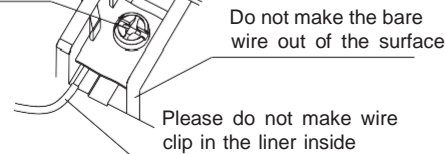

- Connection confirmation
After the end of the wire connection please fully recognized wiring if there is wrong.

CAUTION When Load circuit short circuit occurs, will lead to timing switch failure.

When using a twisted wire

- Please use round plastic pressure terminal with insulating tube (using M4)

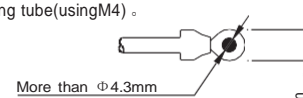

CAUTION

1. when tightening two separate ins, insert them both from the side of the screw as shown on the right.

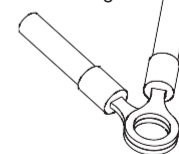

2. Not in a terminal connecting three or more wires. Otherwise it will cause bad contact and lead to a fever, fire and other accident.

CIRCUIT DIAGRAMS

- please draw contains timer switch control equipment of the whole system hookup, Before the wire connection

Time switch and load for the same power occasion.

Use timing switch direct load control

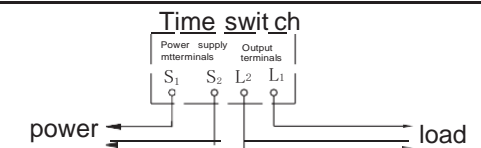

one phase

Load exceeds the rated load, or load for three-phase power.

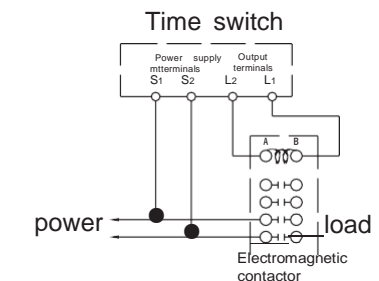

Three phase

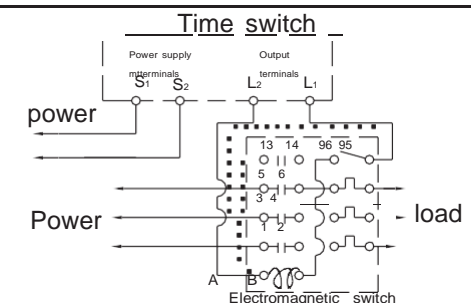

(Caution) Removal of electromagnetic switch transition line, otherwise cannot correct action.