

# BERMIE

## CH series Digital Temperature Controller Instruction Manual



# BERME

---

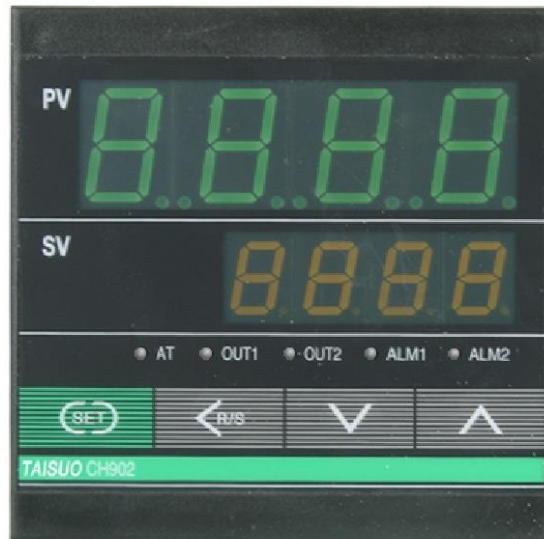

## Panel Description

Code name	Description
<b>PV</b>	Display: process value
<b>SV</b>	Display: setting value
<b>OUT1</b>	Led: light on when output 1 action
<b>OUT2</b>	Led: light on when output 2 action
<b>ALM1</b>	Led: light on when alarm 1 action
<b>ALM2</b>	Led: light on when alarm 2 action
<b>AT</b>	Led: light on when auto-tuning to start
<b>(SET)</b>	Key: change mode or enter
<b>v</b>	Key: changing set value
<b>^</b>	Key: changing set value
<b>&lt;R/S</b>	Key: shift

## Level Description

Take **CH 902 F K02 M\*AB NN** as an example

Level 1		Press " <b>SET</b> " to enter "SV" setting mode			
Character	Description	Setting range	Default setting		
Level 2	<i>RL1</i>	Alarm 1 range	Deviation 10°C	0010	
	<i>RL2</i>	Alarm 2 range	Deviation 10°C	0010	
	Press " <b>SET</b> "  3 seconds	<i>RTU</i>	Auto tuning	0: AT end or AT suspension 1:AT start	0000
		<i>P</i>	Proportional band	1(0.1) to span or 9999(999.9)°C	0030
		<i>I</i>	Integral time	0-3600 s	0240
		<i>d</i>	Differential time	0-3600 s	0060
		<i>Rr</i>	Integral time excluded	0 - 100	0100
		<i>f</i>	Proportioning cycle	1 to 100 sec	0020
		<i>Pc</i>	Proportional band on cool side	1 - 1000%	0100
		<i>t</i>	Proportional cycle on cool side	1 - 100% °C	0002
		<i>Pbr</i>	Cool side compensation	-1999 to +1999 or -199.9 to +999.9°C	0000
		—	Function lock	See instruction manual	0000
		<i>cod</i>	Function lock		
Level 3	Press  " <b>SET</b> "  + " <b>&lt;R/S</b> "	Input signals selection	0 0 0 0	K	0000
			0 0 0 1	J	
			0 0 1 0	E	
			0 0 1 1	N	
			0 1 0 0	R	
			0 1 0 1	S	
			0 1 1 0	B	
			0 1 1 1	T	
			1 0 0 0	Pt100	
			1 0 0 1	CU	
			1 0 1 0	0-5V	
			1 0 1 1	1-5V	
			1 1 0 0	0-20mA	
	1 1 0 1	4-20mA			
	<i>SL2</i>	Unit setting	0 °C 1 F	0000	
Cooling mode setting		0 air cooling 1 water cooling			
<i>SL3</i>	Not available				

Note: when input is current signals, the two connection terminals must connect one 250 resistance.

# BERME

<b>Level 3</b>  Press "SET" + "<R/S"	514	Alarm 1 setting	0 0 0	No alarm 1	0 0 0 1
			0 0 1	Deviation high alarm	
			0 1 0	Deviation high/low alarm	
			0 1 1	Process high alarm	
			1 0 1	Deviation low alarm	
			1 1 0	Band alarm	
			1 1 1	Process low alarm	
			0	No hold action	
	1	With hold action			
	515	Alarm 2 setting	0 0 0	No alarm 2	0 1 0 1
			0 0 1	Deviation high alarm	
			0 1 0	Deviation high/low alarm	
			0 1 1	Process high alarm	
			1 0 1	Deviation low alarm	
			1 1 0	Band alarm	
			1 1 1	Process low alarm	
			0	No hold action	
	1	With hold action			
	516	Control output selection	0	Direct action	0 0 0 1
			1	Reverse action	
0			PID auto-tuning		
1			For mA output selection		
0			Heating time proportional output		
1			For mA output selection		
0			No Out2 function		
1			Out2 is active, it can be relay output and SSR logic output		
517	Alarm relay mode setting	0	Trigger NO → NC alarm 1	0 0 0 0	
		1	Trigger NC → NO		
		0	Trigger NO → NC alarm 2		
		1	Trigger NC → NO		
518	0	RUN/STOP function	off	0 0 0 0	
	1	RUN/STOP function	on		
	0	Auto/Manual mode selection	off		
	1	Auto/Manual mode selection	on		
	0	Communication function	off		
	1	Communication function	on		
	0	Self checking function	off		
	1	Self checking function	on		
519	"SV" alarm selection	0	Alarm 1 "SV" alarm	1 1 1 1	
		1	Alarm 1 "SV" alarm		
		0	Alarm 1 "SV" low alarm		
		1	Alarm 1 "SV" high alarm		
		0	Alarm 2 "SV" alarm		
		1	Alarm 2 "SV" alarm		
		0	Alarm 2 "SV" low alarm		
		1	Alarm 2 "SV" high alarm		

# BERME

<b>Level 4</b> "Cod" = 0001, Press "SET"	SLH	Set high limit of measurement range	For example: thermocouple K 0~400	0400																
	SLL	Set low limit of measurement range	For example: thermocouple K 0~400	0000																
	dP	Bit of the decimal point		0000																
	oH	Dead band of control output	Tc and RTD input :0-100/0.0-100.0	0005																
	AL1	Dead band of alarm1	Tc and RTD input :0-100/0.0-100.0	0005																
	AL2	Dead band of alarm2	Tc and RTD input :0-100/0.0-100.0	0005																
	ATP	Percentage of the set point on Auto-tuning	0~100	0080																
	dF	Filter	0: off 1: on	0001																
<b>Level 5</b> "Cod" = 0010, Press "SET"	Poo	PID output offset	0~100.0%	000.0																
	oPL	Output power limit on Auto/Manual mode	0 - 100.0%	100.0																
	Add	Instrument address setting	0- 1000	0000																
	bPS	Communication speed	0: 2400 bps 1: 4800 bps 2: 9600 bps 3: 19200 bps 4: 38400 bps	0000																
	bIF	Digit structure	<table border="1"> <thead> <tr> <th>Code</th> <th>Bit</th> <th>Checking bit</th> <th>Stop bit</th> </tr> </thead> <tbody> <tr> <td>0</td> <td>8</td> <td>none</td> <td>1</td> </tr> <tr> <td>1</td> <td>8</td> <td>odd</td> <td>1</td> </tr> <tr> <td>2</td> <td>8</td> <td>even</td> <td>1</td> </tr> </tbody> </table>	Code	Bit	Checking bit	Stop bit	0	8	none	1	1	8	odd	1	2	8	even	1	0000
	Code	Bit	Checking bit	Stop bit																
0	8	none	1																	
1	8	odd	1																	
2	8	even	1																	
inf	Delay time setting on communication function	0 - 2000ms	0025																	

# How to press the keys to find the parameters

**Level 1** Press " **SET** " to enter "SV" Setting mode set the value through " <R/S " "  $\sphericalangle$  " and " "

## Level 2

Press " **SET** " 3 seconds

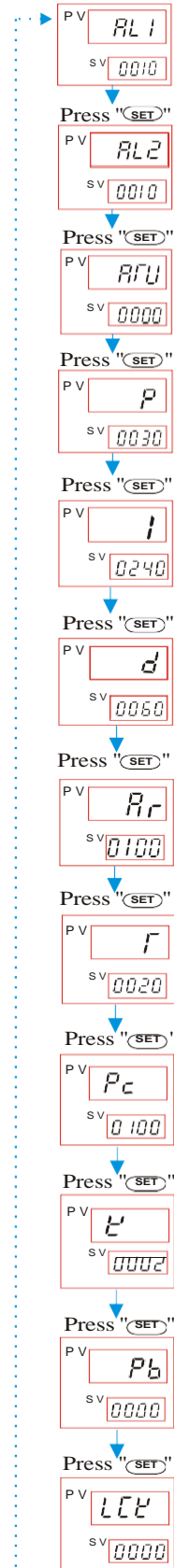

## Level 3

When  $LFP=1000$ , press " **SET** " + " <R/S " to enter Level 3 parameter setting mode.

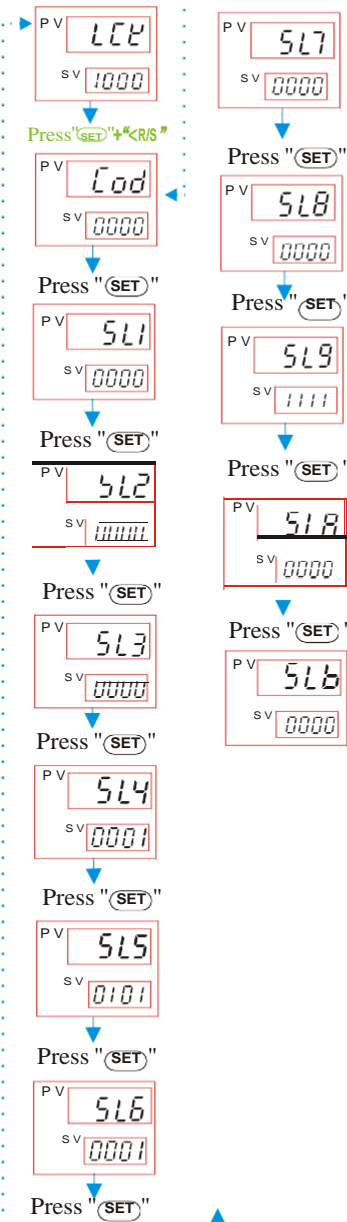

## Level 4

When  $Cod=0001$ , press " **SET** " to enter Level 4 parameter setting mode

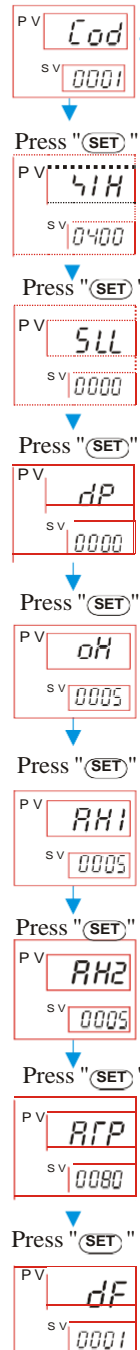

## Level 5

When  $Cod=0010$ , press " **SET** " to enter Level 5 parameter setting mode

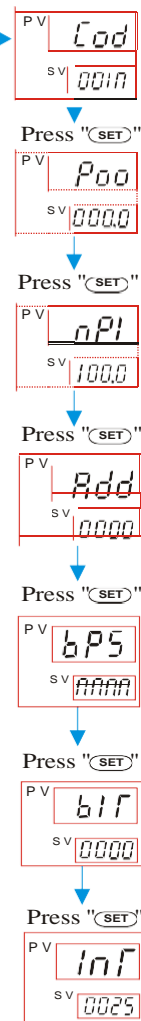

## To show output power percentage



Under Auto controlling, Press **V** to show the output power percentage.

For example:

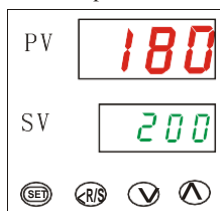

Press **V** key

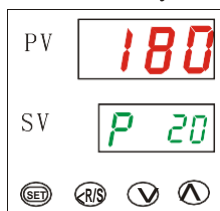

The percentage is calculated by PID

Press **V** key again back to set point displaying mode

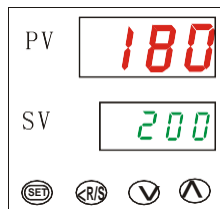

## Auto/Manual mode selection

To use this function, please set S18 parameter to turn on this Auto/Manual mode selection option



Press **R/S** Key 3 seconds to select auto/manual mode.

For example:

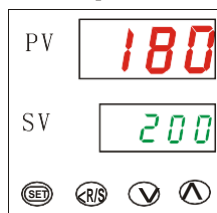

Auto mode

Press **R/S** 3 seconds

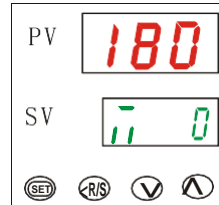

Manual mode output is "0" press "V" "Λ" to select the output setpoint

Press **R/S** 3 seconds Again back to Auto mode

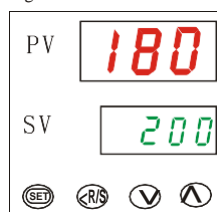

Auto mode

## Product size (unit: mm)

### CH 102

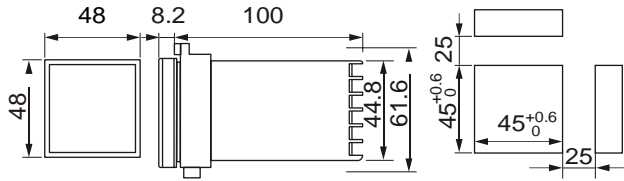

### CH 702

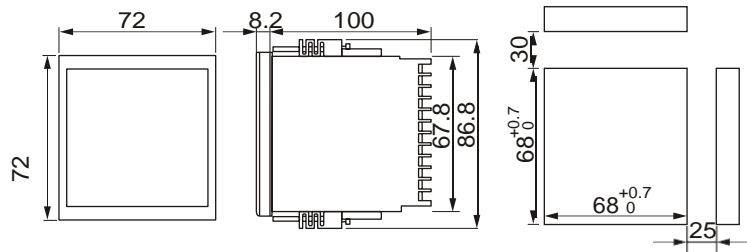

### CH 402

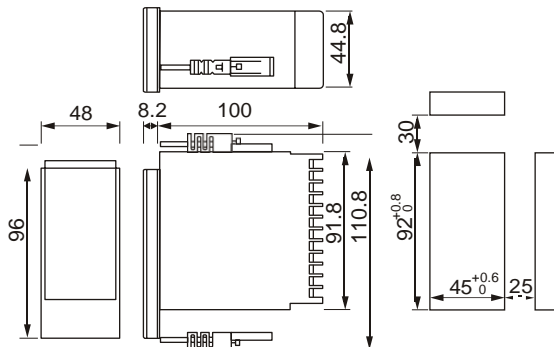

### CH 902

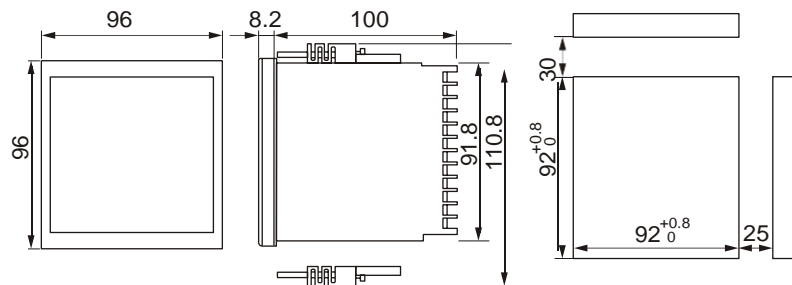



## Ordering code

<b>Model</b>	CH102 48×48mm CH 402 48×96mm CH 702 72×72mm CH 902 96×96mm	F <input type="checkbox"/> <input type="checkbox"/> <input type="checkbox"/> <input type="checkbox"/> -- <input type="checkbox"/> * <input type="checkbox"/> <input type="checkbox"/> -- <input type="checkbox"/> <input type="checkbox"/>
<b>Control action</b>	PID control with AT function	F <input type="checkbox"/>
<b>Input type/Range</b>	See table 1*	<input type="checkbox"/> <input type="checkbox"/> <input type="checkbox"/>
<b>Output</b>	Relay output SSR output Current (mA) output Driving SCR triac output SCR triac output	M V 8 G T
<b>Alarm 1</b>	No alarm 1 Alarm 1 available (See table 2*)	N <input type="checkbox"/>
<b>Alarm 2</b>	No alarm 2 Alarm 2 available (See table 2*)	N <input type="checkbox"/>
<b>Communication</b>	No communication function RS485 interface MODBUS/RTU protocol	N C
<b>Waterproof/ dustproof</b>	No waterproof/dustproof With waterproof/dustproof construction	N 1

**Table 1\* (input type and range option)**

Type	Code	Range
<b>K</b>	01	0 ~ 200℃
	02	0 ~ 400℃
	03	0 ~ 600℃
	04	0 ~ 800℃
	05	0 ~ 1000℃
	06	0 ~ 1200℃
	07	0 ~ 1372℃
<b>J</b>	01	0 ~ 200℃
	02	0 ~ 400℃
	03	0 ~ 600℃
	04	0 ~ 800℃
	05	0 ~ 1000℃
	06	0 ~ 1200℃
<b>R*</b>	01	0 ~ 1600℃
	02	0 ~ 1769℃
<b>S*</b>	01	0 ~ 1600℃
	02	0 ~ 1769℃

Type	Code	Range
<b>B*</b>	01	400 ~ 1800℃
	02	0 ~ 1820℃
<b>E</b>	01	0 ~ 800℃
	02	0 ~ 1000℃
<b>N</b>	01	0 ~ 1200℃
	02	0 ~ 1300℃
<b>T</b>	01	0 ~ 400.0℃
	02	0 ~ 100.0℃
	03	0 ~ 200.0℃
	04	0 ~ 350.0℃

0~20mA	A	01	-1999 ~ 9999
4~20mA	A	02	-1999 ~ 9999
0~5V	V	01	-1999 ~ 9999
1~5V	V	02	-1999 ~ 9999
0~10V	V	03	-1999 ~ 9999
2~10V	V	04	-1999 ~ 9999

Type	Code	Range
<b>Pt100</b>	D 01	-199.9 ~ 649.0℃
	D 02	-199.9 ~ 200.0℃
	D 05	-100.0 ~ 200.0℃
	D 08	0.0 ~ 200.0℃
	D 10	0.0 ~ 500.0℃
<b>Cu50</b>	C 01	0 ~ 200℃
	C 02	0 ~ 400℃
	C 03	0 ~ 600℃
	C 04	0 ~ 800℃
	C 05	0 ~ 1000℃
	C 06	0 ~ 1200℃

Note: do not guarantee the accuracy for the thermocouple type R S B input ranging 0 ~ 399.℃

**Table 2\* (Alarm mode option)**

Code	Alarm mode
A	Deviation high alarm
B	Deviation low alarm
C	Deviation high/low alarm
D	Alarm within range
E	Deviation high alarm with hold action
F	Deviation low alarm with hold action
G	Deviation high/low alarm with hold action
H	Process high alarm
J	Process low alarm
K	Process high alarm with hold action
L	Process low alarm with hold action
R	Control loop break alarm
V	SV high alarm
W	SV low alarm